



Engineering Application of Laplace Transform

Prof. Nita K.Choukade

Prof. Amit P. Mangalekar

*Asst.Prof.in Mathematics Dept., Jagdambha College of Engineering & technology Yavatmal,
Maharashtra, India*

Article details: Received: 11 th May, 2019 Revision: 25 th May, 2019 Accepted: 10 th June, 2019 Published: 12 th June, 2019	Keywords: Laplace Transform, Differential Equation, Linearity, Inverse Laplace Transform, Convolution Theorem
DOI: https://doi.org/10.17762/ijrisat25815814.19030627-36	

ABSTRACT

Basically Laplace Transform will convert function in some domain into a function in another domain, without changing value of the function. In This paper will discuss the various applications of Laplace Transform in different engineering fields. As well as it discuss about, how to solve differential equations by using Laplace Transform, How to find transfer function (T.F.) of mechanical system, How to use Laplace Transform in Nuclear Physics as well as Automation Engineering, Control Engineering and Signal processing.

1. INTRODUCTION

The Laplace Transform is a widely used integral transform in mathematics with many applications in science and engineering. The Laplace Transform can be interpreted as a transformation from time domain where inputs and outputs are functions of time to the frequency domain where inputs and outputs are functions of complex angular frequency. Laplace Transform methods have a key role to play in the modern approach to the analysis and design of engineering system. The concepts of Laplace Transforms are applied in the area of science and technology such as Electric circuit analysis, Communication engineering, Control engineering and Nuclear physics etc.

1.1 Definition and important properties of Laplace Transform

The definition and some useful properties of Laplace Transform which we have to use further for solving problems related to Laplace Transform in different engineering fields are listed as follows.

Definition:-

Let $f(t)$ be a function of t ($t > 0$), then the integral $\int_0^{\infty} e^{-st} f(t) dt$ is called Laplace Transform of $f(t)$.

We denote it as $L[f(t)]$ or $F(s)$.

$$\text{i.e. } L[f(t)] = \int_0^{\infty} e^{-st} f(t) dt = F(s)$$

1.2 Properties of Laplace Transform:-

Linearity Property: If $f(t)$ and $g(t)$ are any two functions of t and α, β are any two constant then, $L[\alpha f(t) + \beta g(t)] = \alpha L[f(t)] + \beta L[g(t)]$

Shifting Property:

If $L[f(t)] = F(s)$, then $L[e^{at} f(t)] = F(s - a)$.

Multiplication by t^n Property:

$L[f(t)] = F(s)$, then

Laplace Transform of Derivative:

$$L[t^n f(t)] = (-1)^n \frac{d^n}{ds^n} [F(s)]$$

If $L[f(t)] = F(s)$, then

$$L[f^{(n)}(t)] = s^n F(s) - s^{n-1} f(0) - s^{n-2} f'(0) - s^{n-3} f''(0) - \dots - f^{(n-1)}(0).$$

Laplace Transform of Bessel's function:

$$L[J_0(t)] = \frac{1}{\sqrt{s^2+1}}, \text{ where}$$

$$J_0(t) = \sum_{k=0}^{\infty} (-1)^k \frac{(\frac{t^2}{4})^k}{(k!)^2} \text{ (Bessel's function).}$$

Inverse Laplace Transform:

$L[f(t)] = F(s)$, then

$$L^{-1}[F(s)] = f(t) \text{ (Inverse Laplace Transform of } F(s)\text{).}$$

Inverse Laplace Transform by Convolution Theorem:

If $L^{-1}[\phi_1(s)] = f_1(t)$; $L^{-1}[\phi_2(s)] = f_2(t)$ then,

$$L^{-1}[\phi_1(s) \cdot \phi_2(s)] = \int_0^t f_1(u) \cdot f_2(t-u) du$$

2. APPLICATIONS

2.1 Laplace Transform in Science and Engineering fields:-

This section describes the applications of Laplace Transform in the area of science and engineering. The Laplace Transform is widely used in following science and engineering field.

A. Analysis of electronic circuits:

Laplace Transform is widely used by electronic engineers to solve quickly differential equations occurring in the analysis of electronic circuits.

B. System modeling:

Laplace Transform is used to simplify calculations in system modeling, where large number of differential equations is used.

c. Digital signal processing:

One cannot imagine solving digital signal processing problems without employing Laplace Transform.

D. Nuclear Physics:

In order to get the true form of radioactive decay a Laplace Transform is used. It makes easy to study analytic part of Nuclear physics possible.

E. Process Control:

Laplace Transform is used for process controls. It helps to analyze the variables which when altered, produce desired manipulations in the result.

Some of the examples in science and engineering fields in which Laplace Transforms are used to solve the differential equations occurred in these fields. The following examples highlight the importance of Laplace Transform in different engineering fields.

2.2 Laplace Transform to solve Differential Equation:

Ordinary differential equation can be easily solved by the Laplace Transform method without finding the general solution and the arbitrary constants. The method is illustrated by following example,

$$x \frac{d^2y}{dx^2} + \frac{dy}{dx} + xy = 0$$

Differential equation is

Taking Laplace Transform on both sides, we get

$$\begin{aligned} L[xy''] + L[y'] + L[xy] &= 0 \\ \therefore \text{given } y(0) = 2, y'(0) = 0 \\ \therefore \frac{d}{ds} L[y''] + L[y'] + \frac{d}{ds} L[y] &= 0 \\ \therefore -\frac{d}{ds} \{s^2 \bar{y} - sy(0) - y'(0)\} + \{s\bar{y} - y(0)\} - \frac{d}{ds} (s\bar{y}) &= 0 \end{aligned}$$

Putting boundary conditions,

$$\begin{aligned} \therefore -\frac{d}{ds} \{s^2 \bar{y} - 2s - 0\} + \{s\bar{y} - 2\} - \frac{d}{ds} (s\bar{y}) &= 0 \\ y(0) = 2 \text{ and } y'(0) = 0 \\ \therefore (s^2 + 1) \frac{d\bar{y}}{ds} + s\bar{y} &= 0 \end{aligned}$$

Separating the variables, we get

$$\begin{aligned} \frac{d\bar{y}}{\bar{y}} + \frac{s ds}{s^2 + 1} &= 0 \\ \therefore -s^2 \frac{d\bar{y}}{ds} - 2s\bar{y} + 2 + s\bar{y} - 2 - \frac{d\bar{y}}{ds} &= 0 \end{aligned}$$

Integrating both sides, we get

$$\log \bar{y} + \frac{1}{2} \log(s^2 + 1) = \log C$$

Taking Inverse Laplace Transform, we get

$$y = L^{-1} \left[\frac{C}{\sqrt{s^2 + 1}} \right] \quad \therefore \log \bar{y} = \log C - \log(\sqrt{s^2 + 1})$$

i.e. $y = C J_0(x)$

At $x = 0$, $y(0) = C J_0(0)$ Putting $y(0) = 2$ and $J_0(0) = 1$, we get,

$$C=2$$

Required value of y is,

$$Y=2J_0(x)$$

2.3 Laplace Transform in Simple Electric Circuits:

$$y = 2J_0(x)$$

Consider an electric circuit consisting of a resistance R, inductance L, a condenser of capacity C and electromotive power of voltage E in a series. A switch is also connected in the circuit, then by Kirchhoff's law, we get

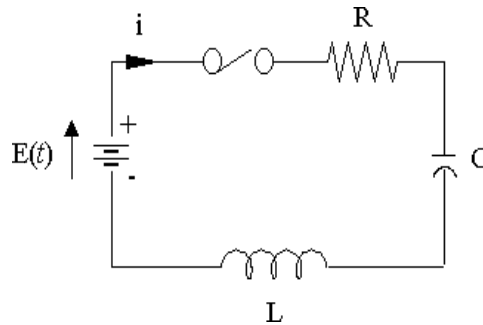

$$L \frac{di}{dt} + Ri + \frac{q}{C} = E$$

$$y = 2J_0(x)$$

Example: An inductance of 3 Henry, a resistor of 16 ohms and a capacitor of 0.02 farad are connected in series with an emf of 300 volts. At $t=0$, the charge on the capacitor and current in the circuit is zero. Find the charge and current at any time $t>0$.

Solution:

Let Q and i be instantaneous charge and current respectively at time t ,

Then by Kirchhoff's law

$$L \frac{di}{dt} + Ri + \frac{q}{C} = E$$

$$\therefore \bar{y} = \frac{C}{\sqrt{s^2+1}}$$

$$2 \frac{d^2Q}{dt^2} + 16 \frac{dQ}{dt} + 50Q = E \dots \{ \because I = \frac{dQ}{dt} \}$$

$$\therefore \frac{d^2Q}{dt^2} + 8 \frac{dQ}{dt} + 25Q = 150$$

Applying Laplace Transform on both sides,

$$\therefore \{s^2L[Q] - sQ(0) - Q'(0)\} + 8\{sL[Q] - Q(0)\} + 25L[Q] = 150L[1]$$

$$L \left[\frac{d^2Q}{dt^2} \right] + 8L \left[\frac{dQ}{dt} \right] + 25L[Q] = L[150]$$

$$\therefore s^2L[Q] + 8sL[Q] + 25L[Q] = \frac{150}{s}$$

$$s^2 + 8s + 25)L[Q] = \frac{15U}{s}$$

$$\therefore L[Q] = \frac{15U}{s(s^2 + 8s + 25)}$$

Taking Inverse Laplace Transform on both sides,

$$\therefore Q = L^{-1}\left[\frac{15U}{s(s^2 + 8s + 25)}\right]$$

Therefore By method of partial fraction

$$Q = L^{-1}\left[\frac{6}{s} - \frac{6s + 48}{(s^2 + 8s + 25)}\right]$$

$$\therefore Q = 6L^{-1}\left[\frac{1}{s}\right] - L^{-1}\left[\frac{6(s + 4)}{(s + 4)^2 + 9}\right] - L^{-1}\left[\frac{24}{(s + 4)^2 + 9}\right]$$

Using shifting property

$$Q = 6 - 6e^{-4t} \cos 3t - 8e^{-4t} \sin 3t$$

$$\text{And } \frac{dQ}{dt} = 50e^{-4t} \sin 3t$$

This is required expression for charge and current at any time $t > 0$.

3. Theory of Automatic Control

A mechanism, whether it involves electrical, mechanical or other principles, designed to accomplish such automatic control is called a servomechanism.

Suppose that a missile M is tracking down enemy aircraft. If at time t the enemy turns through some angle $\phi(t)$, the M must also turn through this angle, if it is to be catch with and destroy it. If a mass was aboard M, anyone could operate.

$$L \frac{dI}{dt} + RI + \frac{Q}{C} = E$$

Some steering mechanism to produce required turns, but since the missile is must be accomplished automatically. To do for man eyes, such as a radar beam which will indicate or point to the direction which must be taken by M, we also need something providing a substitute for a man's hands which will turn a shaft through some angle in order to produce the desire turn.

In this application, let us assume that the desired angle of turn as indicated by the radar beam is < 0 Also let $\theta(t)$ denotes the angle if turn of the shaft

at time. Because the things are happening so fast we must

Except to have a error between two.

$$\therefore [s^2L[Q] - sQ(0) - Q'(0)] + 8[sL[Q] - Q(0)] + 25L[Q] = 150L[1]$$

$$\therefore \text{error} = \theta(t) - at$$

The existence of the error must be signaled back to the shaft, so that a compensating turning efforts or torque be produced. If the error is large the torque needed will be large. If the error is small the torque needed will be small. So that requires torque is proportional to the error.

$$\text{Torque} = I \frac{d^2 \theta}{dt^2}$$

i.e. M.I. multiplied by angular acceleration. Since torque is directly

$$\therefore I \frac{d^2 \theta}{dt^2} \propto [\theta(t) - \alpha t]$$

proportional to error,

$$\therefore I \frac{d^2 \theta}{dt^2} - k[\theta(t) - \alpha t] \dots (i)$$

Where $k < 0$

The minus sign is used because if the error is positive then the torque must be opposite it. While the error is negative the torque must be positive. Assuming that the initial angle and angular velocity are zero as possible conditions,

$$\text{i.e. } \theta(0) = 0, \text{ and } \theta'(0) = 0$$

Therefore from equation (i)

$$\begin{aligned} I \frac{d^2 \theta}{dt^2} &= k\theta(t) - k\alpha t \\ \Rightarrow \frac{d^2 \theta}{dt^2} + \frac{k}{I} \theta(t) &= \frac{k}{I} \alpha t \end{aligned}$$

Taking Laplace Transform on both sides,

$$L \left[\frac{d^2 \theta}{dt^2} \right] + \frac{k}{I} L[\theta(t)] = \frac{k}{I} L[\alpha t]$$

$$\Rightarrow s^2 L[\theta] - s\theta(0) - \theta'(0) + \frac{k}{I} L[\theta] = \frac{k}{I} \alpha \frac{1}{s^2}$$

$$\Rightarrow \left(s^2 + \frac{k}{I} \right) L[\theta] = \frac{k}{I} \alpha \frac{1}{s^2}$$

{using $\theta(0) = 0$, and $\theta'(0) = 0$ }

$$\Rightarrow L[\theta] = \frac{k}{I} \left[\frac{\alpha}{s^2 \left(s^2 + \frac{k}{I} \right)} \right]$$

Taking Inverse Laplace Transform on both sides,

$$\theta = \frac{k}{I} L^{-1} \left[\frac{\alpha}{s^2 \left(s^2 + \frac{k}{I} \right)} \right]$$

$$\therefore \theta = \frac{k\alpha}{I} \left[L^{-1} \left(\frac{1}{s^2} \right) * L^{-1} \left(\frac{1}{s^2 + \frac{k}{I}} \right) \right]$$

By convolution theorem,

$$\theta = \frac{k\alpha}{I} \int_0^t u \frac{1}{\sqrt{k/I}} \sin \sqrt{\frac{k}{I}} (t-u) du$$

$$\therefore \theta = \alpha \sqrt{\frac{k}{I}} \int_0^t u \sin \sqrt{\frac{k}{I}} (t-u) du$$

..... { Integration by parts rule

$$\begin{aligned} \therefore \theta &= \alpha \sqrt{\frac{k}{I}} \left\{ \left[u \cdot \frac{1}{\sqrt{k/I}} \cos \sqrt{\frac{k}{I}}(t-u) \right]_0^t - \int_0^t \frac{1}{\sqrt{k/I}} \cos \sqrt{\frac{k}{I}}(t-u) du \right\} & \therefore \bar{N} &= \frac{N_0}{s+\lambda} \\ \therefore \theta &= \alpha \sqrt{\frac{k}{I}} \left\{ \left[\frac{t}{\sqrt{k/I}} \right] + \left[\frac{I}{k} \sin \sqrt{\frac{k}{I}}(t-u) \right]_0^t \right\} \\ \therefore \theta &= \alpha \sqrt{\frac{k}{I}} \left\{ \sqrt{\frac{I}{k}} t - \frac{I}{k} \sin \sqrt{\frac{k}{I}} t \right\} \\ \therefore \theta(t) &= \alpha t - \alpha \sqrt{\frac{I}{k}} \sin \sqrt{\frac{k}{I}} t \end{aligned}$$

This is the required turn at any time.

3.1 Laplace Transform in Nuclear Physics:-

The following example is based on concepts from nuclear physics. Consider the following first order linear differential equation.

$$\frac{dN}{dt} = -\lambda N$$

This equation is the fundamental relationship describing radioactive decay, where $N = N(t)$ represents the number of undecayed atoms remaining in a sample of a radioactive isotope at time t and λ is the decay constant. We can use the Laplace Transform to solve this equation. Rearranging the above equation, we get

$$\frac{dN}{dt} + \lambda N = 0$$

Taking Laplace Transform on both sides,

$$sL[N] - N(0) + \lambda L[N] = 0$$

$$\therefore s\bar{N} - N_0 + \lambda\bar{N} = 0$$

$$\dots \{ \text{here } L[N] = \bar{N} \text{ and } N(0) = N_0 \}$$

Now, Taking Inverse Laplace Transform on both sides, we get which is indeed the correct form for radioactive decay.

$$N(t) = N_0 e^{-\lambda t}$$

3.2 Laplace Transform in Control Engineering:

a) Mechanical Engineering:-

In Mechanical engineering field Laplace Transform is widely used to solve differential equations occurring in mathematical modeling of mechanical system to find transfer function of that particular system. Following example describes how to use Laplace Transform to find transfer function.

Example:

The tank shown in figure is initially empty ($t = 0$). A constant rate of flow Q_i is

added for the rate at which flow leaves the tank is $Q_o = CH$. the cross sectional area of the tank is A. Determine the differential equation for the head Identify the time constant and find the transfer function of system.

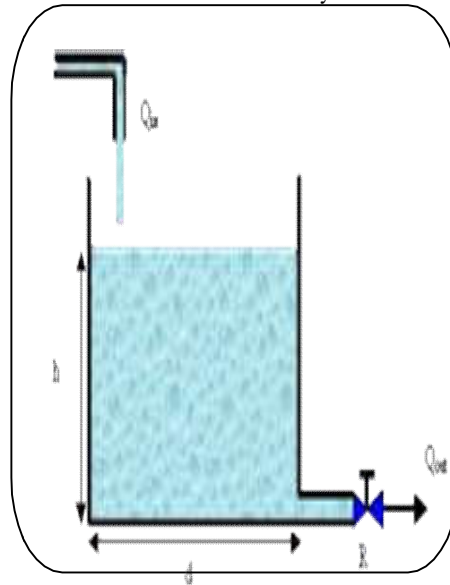

Solution:

Given that $Q_o = CH$

Let, M=Mass of fluid

e=Density of fluid

Therefore Mass= M= Volume X Density = AH X e

Therefore Mass Flow Rate= M= dH/dt

= d/dt(AH X e)= eA X dH/dt

We Know That,

Mass Flow Rate into tank=Mass in flow rate – Mass out flow rate.

$$\therefore eA \frac{dH}{dt} = eQ_i - eQ_o$$

$$\therefore A \frac{dH}{dt} = Q_i - Q_o$$

$$\therefore A \frac{dH}{dt} = Q_i - CH$$

$$\dots\dots Q_o = CH \quad \}$$

$$\therefore Q_i = A \frac{dH}{dt} + CH$$

This equation represents the differential equation for head H.

Now, Taking Laplace Transform on both sides,

$$L[Q_i] = A_s L \left[\frac{dH}{dt} \right] + C_s L[H]$$

$$\dots\dots \{ \because H(0) = 0$$

$$\therefore Q_i(s) = A_s \{sH(s) - H(0)\} + C_s H(s)$$

$$\therefore Q_i(s) = A_s \cdot sH(s) + C_s H(s)$$

$$\therefore Q_i(s) = (sA_s + C_s) H(s)$$

$$\therefore \frac{H(s)}{Q_i(s)} = \frac{1}{sA_s + C_s} \dots\dots(i)$$

$$\text{But } Q_o = CH$$

Taking Laplace Transform, we get

$$Q_o(s) = C_s H(s)$$

$$\therefore H(s) = \frac{Q_o(s)}{C_s}$$

Using this in equation (i), we get

This equation represents the transfer function of system.

$$\frac{Q_o(s)}{C_s Q_i(s)} = \frac{1}{sA_s + C_s} \quad \therefore \frac{Q_o(s)}{Q_i(s)} = \frac{1}{1 + \left(\frac{A_s}{C_s}\right)s}$$

Therefore time constant, $\tau = \frac{A_s}{C_s}$

4. CONCLUSION

Through this paper we present the applications of Laplace Transform in different engineering fields, like Electronics, Mechanical, Physics etc. Besides these, Laplace Transform is a very effective tool to simplify very complex problems in the area of stability and control. It goes without saying that Laplace Transform is put to tremendous use in engineering field.

REFERENCES

- [1] B.V. Ramanna, Higher Engineering Mathematics, Tata Mc- Graw Hill Publication.
- [2] H.K.Dass and Er. Rajnish Verma, Higher Engineering Mathematics, S. Chand Publication, New Delhi.
- [3] Sarina Adhikari, Laplace Transform and its applications, University of Tennessee. (Department of Electrical Engineering).
- [4] Sunil Shrivastava , Department of Mathematics AISECT University India , Introduction of Laplace Transform and Elzaki. Scientific and Research Publications, ISSN 2250-3153, August 2016.
- [5] I.J.Nagrath and M. Gopal, Control System Engineering, New age international Publication.
- [6] Gopal, Control Systems Principles and Design, 3rd edition, Tata McGraw Hill Publication.
- [7] S. Palani, Automatic Control System, 2nd edition, Ane Books Pvt.ltd. M. Peer

Mohamed, Department of Mathematics, Marudupandiyar College, Thanjavur, IJSRP, Vol 6, Aug 2016, ISSN 2250-3553.

- [8] L.S. Sawant, Department of Mathematics, DKTE Society's Textile & Eng. Institute, Ichalkaranji, Maharashtra, India, 'Applications of laplace transform in engineering fields' e-ISSN: 2395-0056, Volume: 05 Issue: 05 | May-2018, Pg.No.3100-3105.

How to Cite this Articles:

Nita K.Choukade and Amit P. Mangalekar, "Engineering Application of Laplace Transform" International Journal of Research in Informative Science Application & Techniques (IJRISAT), 3(6) 2019:193627-36.

DOI: <https://doi.org/10.17762/ijrisat25815814.19030627-36>